

Level-I Controlled Substances are banned

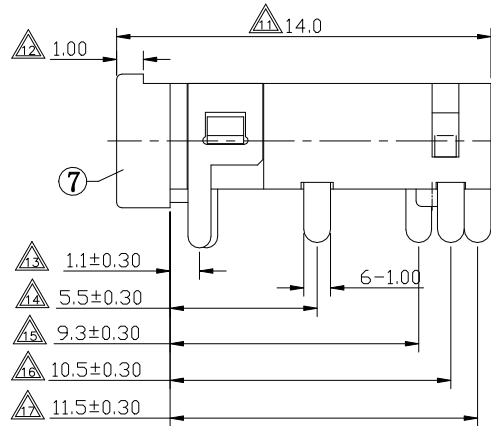

P.C.B LAYOUT
TOP VIEW

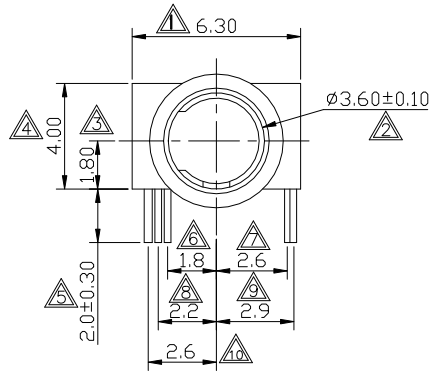
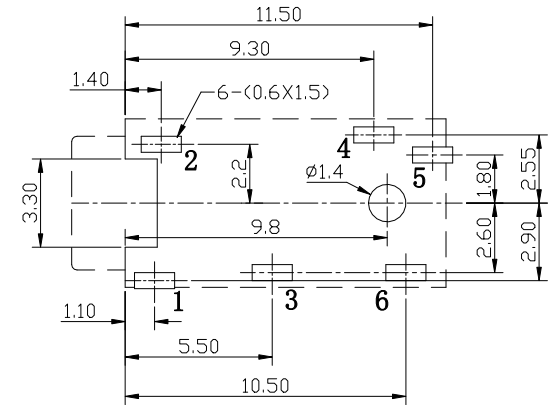

SCHEMATIC

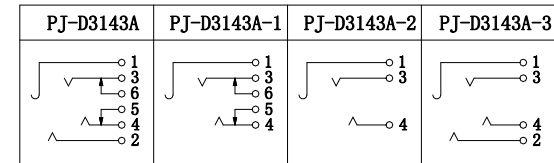

- SPECIFICATION**
- 1.Rating : DC 30V 0.5A;
 - 2.Contact resistance: $\leq 0.03\Omega$;
 - 3.Insulation resistance: $\geq 100M\Omega$ (DC250V);
 - 4.Withstand voltage: 500VAC ;
 - 5.Insertion and extraction force: 3-30N;
 - 6.life test: 5,000 cycles.
 - 7.Marked \triangle are important dimensions.

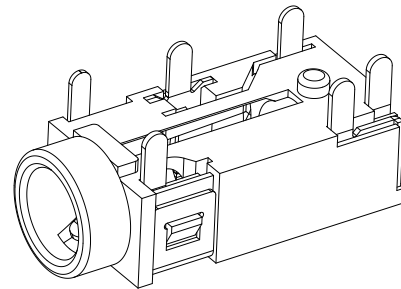
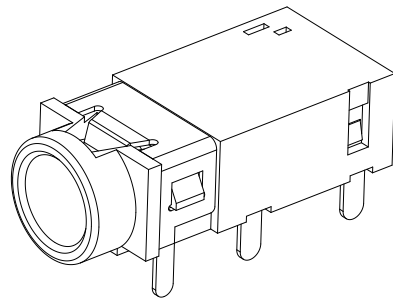
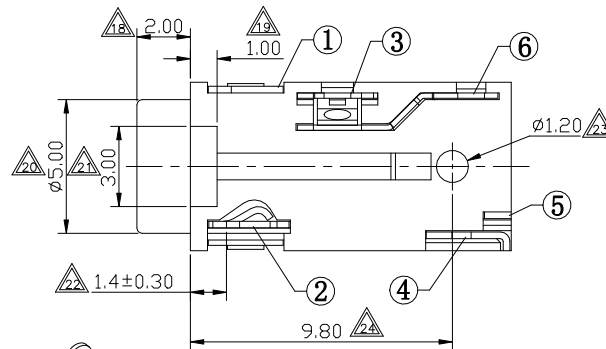

NO.	DESCRIPTION	QTY	MATERIAL	COLOR	REMARK
7	HOUSING	1	PA9T	—	—
6	6#CONTACT FOOT	1	PHOSPHOR BRONZE	—	Au-Plating
5	5#CONTACT FOOT	1	PHOSPHOR BRONZE	—	Au-Plating
4	4#CONTACT FOOT	1	SUS301	—	Au-Plating
3	3#CONTACT FOOT	1	SUS301	—	Au-Plating
2	2#CONTACT FOOT	1	PHOSPHOR BRONZE	—	Au-Plating
1	1#CONTACT FOOT	1	PHOSPHOR BRONZE	—	Au-Plating

GENERAL TOLERANCE UNLESS OTHERWISE SPECIFIED		盛聰电子有限公司 SHENG CONG ELECTRONIC CO.,LTD	
General	Angle	CUSTOMER COPY	TITLE: PHONE JACK
X ± 0.50	X ° ± 3°		PART NO. PJ-D3143A
X.X ± 0.30	X.X ° ± 2°	SCALE: 4:1	
X.XX ± 0.20	X.XX ° ± 1°	SIZE: A4	SHEET: 1 OF 1
X.XXX ± 0.10			

ECN(OCN) NO.	REV	DATE	DESCRIPTION	CHANGE	APPRO.	DESIGN	DATE
	0	12'/07/09	NEW	JASON	Max.hu	Jason	12'/07/09
						Jason	12'/07/09
						Max.hu	12'/07/09